

REV.	ECN.NO.	NAME	DATA
A0	NEW	MIN-D	2020-11-24

SPECIFICATION NOTES:

ELECTRICAL:

1. VOLTAGE RATING: 125 VAC RMS
2. CURRENT RATING: 1.5 AMP
3. CONTACT RESISTANCE: 30mΩ MAX.
4. INSULATION RESISTANCE: 1000MΩMIN. AT 500V DC.
5. DIELECTRIC STRENGTH: 1000 VAC 50Hz 1MINUTE

MECHANICAL:

1. HOUSING MATERIAL:
SEE PART NUMBER.
2. CONTACTS: $\phi 0.46$ mm PHOSPHOR BRONZE, GOLD PLATING OVER NICKEL
3. OPERATING LIFE: 750 CYCLES MIN.
4. MATING FORCE: 30N MAX.
UNMATING FORCE: 30N MAX.

ENVIRONMENTAL:

1. STORAGE: -40°C TO +85°C
2. OPERATION: -40°C TO +85°C

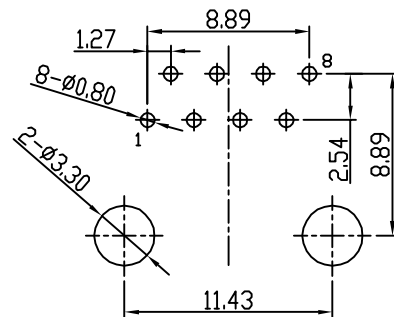
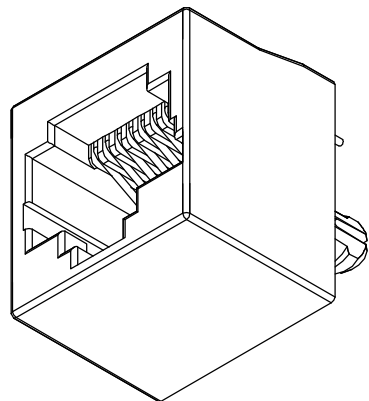
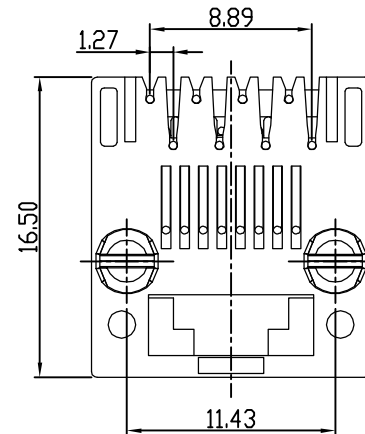
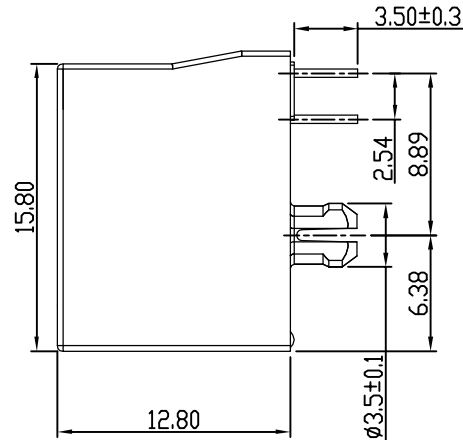
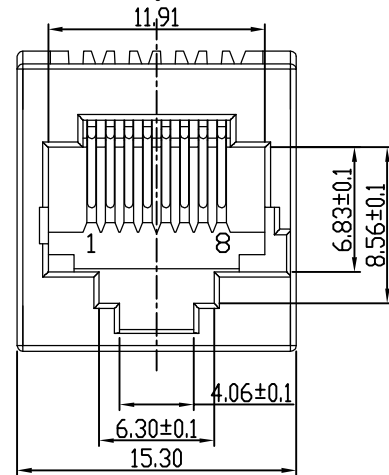
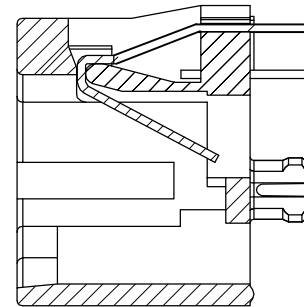
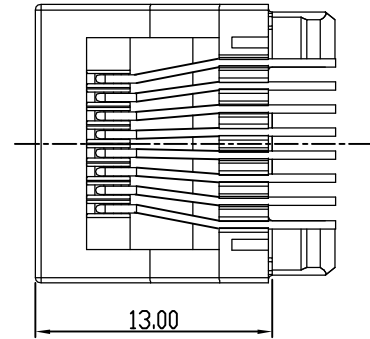
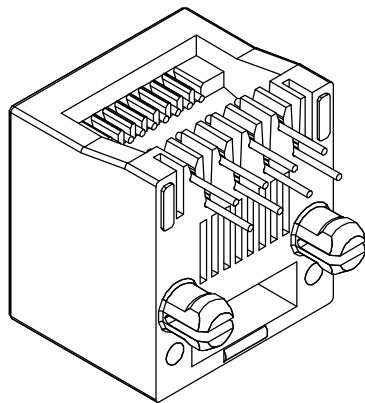

Recommend PCB Layout
THICKNESS=1.6mm
TOLERANCES: ±0.05

MM (INCH)		绘图 (Designed) MIN-D 2020-11-24	
公差 TOLERANCES		审核 (Checked)	
MM	MM	批准 (Approved)	
.0 ± 0.20	.0 ± 0.38	材料 (Material)	
.00 ± 0.15	.00 ± 0.25	比例 (SCALE) 1:1	
.00 ± 0.075	.000 ± 0.15	DETACHED LISTS	
角度 (ANGLES) ± 1.5°		第三视图	

Coorle 库乐科技

系列 (SERIES)	名称 (NAME)	版本 REV.	图号 (DWG NO.):
RJ	5222-A 8P8C 短体 无耳	A0	料号 (PART NO):
单位 (UNIT): MM		共 (SHEET) 1	页第 (OF) 1